

# SAFEONE XS

## Manual

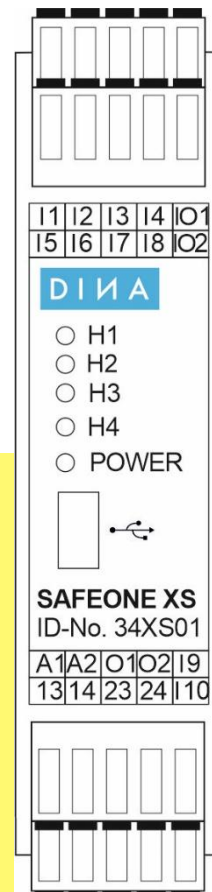

## **DINA Elektronik GmbH**

Esslinger Straße 84  
72649 Wolfschlugen  
Deutschland

Phone +49 7022 9517 0  
Mail [info@dina.de](mailto:info@dina.de)  
Web [www.dina.de](http://www.dina.de)

### **© Copyright by DINA Elektronik GmbH 2026**

All parts of this documentation are protected by copyright.

Any use beyond that permitted under copyright law is not permitted without express written consent from the publisher. This applies in particular to the reproduction, distribution and translation of this documentation or parts thereof, as well as the storage and processing of this content using electronic data processing systems.

The information contained in this documentation corresponds to the technical state of the product at the time these operating instructions were published.

This manual is valid for:

<b>Description</b>	<b>ID-No.</b>
--------------------	---------------

SAFEONE DS	34XS01
------------	--------

### **Legal information**

Handbook:	Manual
Target group:	Electricians, electrical designers
Editor:	DINA Elektronik GmbH
File name:	SAFEONE XS_Handbuch-en-V01.docx
Language:	ENG
Publication as at:	February 5, 2026

## Table of Contents

<b>1</b>	<b>Structure of the document</b> .....	<b>2</b>
1.1	Conventions.....	2
1.1.1	Emphasizing information .....	2
1.1.2	Emphasizing paragraphs using typography .....	2
1.1.3	Emphasizing words using typography .....	2
1.2	Your opinion is important to us!.....	3
<b>2</b>	<b>Safety</b> .....	<b>4</b>
2.1	Warnings .....	4
2.1.1	Function of warnings .....	4
2.1.2	Design of warnings.....	4
2.1.3	Hazard symbols.....	5
2.2	Qualification of personnel .....	5
2.2.1	Electrician.....	5
2.2.2	Electrical designers .....	5
2.3	Intended use and improper use .....	6
2.3.1	Certification data .....	6
<b>3</b>	<b>EC declaration of conformity</b> .....	<b>10</b>
<b>4</b>	<b>Product description</b> .....	<b>11</b>
4.1	Connections.....	11
4.2	Block diagram.....	12
4.3	Diagnostics and switching status displays .....	12
<b>5</b>	<b>Example of application</b> .....	<b>13</b>
<b>6</b>	<b>Order information</b> .....	<b>14</b>
<b>7</b>	<b>Technical data</b> .....	<b>14</b>
7.1	Supply .....	14
7.2	Digital inputs .....	14
7.3	Analog inputs.....	14
7.4	Transistor outputs.....	14
7.5	Contact outputs .....	15
7.6	General data.....	15
7.7	Connection data .....	16

7.8	Environmental conditions.....	16
7.9	Dimensions.....	16
7.10	Safety-related parameters in accordance with DIN EN ISO 13849-1:2016-06 .....	16
7.11	Safety-related parameters in accordance with EN ISO 61508-High Demand.....	17
7.12	Contact life .....	17
<b>8</b>	<b>Installation and removal.....</b>	<b>18</b>
8.1	Installing a module.....	18
	8.1.1 Overview .....	18
8.2	Removing a module.....	18

# 1 Structure of the document

## 1.1 Conventions

Information of particular importance is emphasized in this documentation through the use of symbols, typography or formulations.

### 1.1.1 Emphasizing information

The following symbols indicate important information:



Degree of hazard (e.g. WARNING): Triangular symbols indicate the degree of hazard in warnings.

---



Type of hazard (e.g. electrical shock – dangerous voltage): Triangular symbols indicate the type of hazard in warnings.

---



Information: Additional clarification.

---



Tip: Additional information to help optimize the workflow.

### 1.1.2 Emphasizing paragraphs using typography

The following typography is used to emphasize paragraphs with special functions:



Indicates an instruction.

---



Indicates an expected reaction.

---



Indicates an unexpected reaction.

---



Indicates an item in a list.

### 1.1.3 Emphasizing words using typography

The following typography is used to emphasize words with special functions:

**(1)**

Represents a numbered item in a figure.

---

→

Indicates a cross-reference to another page, figure or document.

## **1.2 Your opinion is important to us!**

We do all we can to provide complete, accurate documentation for the product. If you have any suggestions for improvement or advice for us, please share your thoughts with us. Send us your comments by e-mail to the following address.

E-mail: [info@dina.de](mailto:info@dina.de)

## 2 Safety

### 2.1 Warnings

#### 2.1.1 Function of warnings

Warnings warn users about hazards when handling the product. The hazards are classified, specified, described and supplemented with information about how to avoid them.

- If there is a warning before a list of instructions, the hazard is present throughout the entire activity.
- If there is a warning immediately before an instruction, the hazard is present during the next step.

#### 2.1.2 Design of warnings

All warnings are indicated by a signal word and a warning symbol. The different combinations of the signal word and warning symbol indicate the degree of danger.

---

**DANGER**

For an immediate hazard that will result in severe injuries or death.

---

**WARNING**

For an immediate hazard that could result in severe injuries or death.

---

**CAUTION**

For a potentially hazardous situation that could result in injuries.

---

**CAUTION**

For a potentially harmful situation in which the product or an item near it could be damaged.

---

**CAUTION**

For a hazard that could cause environmental damage.

---

### 2.1.3 Hazard symbols

---

**Note**

The warning symbol may be present alongside another hazard symbol that represents the type of hazard, in order to attract the reader's attention.

---

Hazard symbols are indicated by a triangular symbol in the context of warnings. The following hazard symbols are used in this documentation:

---



Electric shock – dangerous voltage!

---

## 2.2 Qualification of personnel

**DINA Elektronik GmbH** distinguishes between specialist staff with different qualifications when it comes to carrying out work on the product. The minimum required qualifications are specified for each task and are defined as follows:

### 2.2.1 Electrician

Specialist, who installs, maintains and repairs the electrical system in the product. A specialist is a person whose specialist training means that they have the knowledge and experience, including knowledge of relevant regulations, necessary to assess the work assigned to them and the potential hazards.

---

**Note**

When evaluating a person's specialist training, multiple years of work in the relevant field may also be taken into account.

→ **DIN VDE 1000-10** Requirements for persons working in a field of electrical engineering.

---

### 2.2.2 Electrical designers

Specialists, who design the electrical system and the product. A specialist is a person whose specialist training means that they have the knowledge and experience, including knowledge of relevant regulations, necessary to assess the work assigned to them and the potential hazards.

---

**Note**

When evaluating a person's specialist training, multiple years of work in the relevant field may also be taken into account.

→ **DIN VDE 1000-10** Requirements for persons working in a field of electrical engineering.

---

## 2.3 Intended use and improper use

The product has exclusively been developed for use for the purpose described here. The specifications set out in these operating instructions must be strictly complied with.

- **SAFEONE XS** is a safety switchgear
- The safety module is intended for use on machines and plants to prevent hazards from arising.

Any other form of use is regarded as improper use.

If the product is

- not used as intended,
- improperly maintained or
- incorrectly operated,

the manufacturer will not assume any liability for any damage that results. In this case, the risk shall be borne exclusively by the user.

### 2.3.1 Certification data

The product is certified as safety equipment in accordance with:

<ul style="list-style-type: none"> <li>▪ DIN EN ISO 13849-1:2016-06, Category 3, PLd</li> </ul>	
<ul style="list-style-type: none"> <li>▪ DGUV Test: GS-ET-20:2016-10</li> <li>▪ EC type examination certificate</li> </ul>	Notified body: <b>DGUV Test</b> Prüf- und Zertifizierungsstelle, Elektrotechnik, Fachbereich: ETEM Gustav-Heinemann-Ufer 130 D-50968 Köln (Reg.-Nr.: 0340)
<ul style="list-style-type: none"> <li>▪ EMC Directive</li> </ul>	Certified by: ELMAC GmbH Bondorf
<ul style="list-style-type: none"> <li>▪ CNL, USL</li> </ul>	File E227037
<ul style="list-style-type: none"> <li>▪ QA system certified as per DIN EN ISO 9001:2015</li> </ul>	Certified by: DQS GmbH, 60433 Frankfurt am Main, Germany

**Note**

You can download the certificates from our website:

→ <https://www.dina.de/downloads>

---

## 2.4 Documentation

Operating instructions contain instructions on how to use a product safely, correctly and cost-effectively. Follow the instructions in these operating instructions in order to prevent hazards, avoid repair costs and standstill, and improve the reliability and service life of the product. You must read the operating instructions and ensure that you understand them.

---



- ▶ Before working with the product, read the documentation

You can find them at [www.dina.de/downloads](http://www.dina.de/downloads)

- ▶ Always ensure that the operating instructions are available where the product is in use.
- 

## 2.5 Safety regulations

The safety regulations listed below must always be complied with. In the event that these safety regulations are not complied with or the device is used improperly, **DINA Elektronik GmbH** accepts no liability for any resulting injury or damage.

- The product must only be installed and commissioned by a skilled electrician or a trained, instructed person, who is familiar with these operating instructions and the applicable specifications regarding occupational health and safety and accident prevention.
- 

**WARNING**

**Danger to persons and materials!** In the event that specifications are not complied with, this can result in death, severe injuries or significant material damage.

- ▶ Observe VDE, EN and local regulations, in particular with regard to protective measures.
- 
- If the emergency stop is used, either the integrated restart prevention function must be used or the machine must be prevented from restarting automatically using a superordinate control system.
  - When installing the device, the required distances as per DIN EN 50274, VDE 0660514 must be taken into account.
- ▶ During transport, storage and operation, comply with the conditions set out in EN 60068-2-1, 2-2.
  - ▶ Assemble the device in a control cabinet with at least IP54 degree of protection. Otherwise, dust and moisture can impair the functions. The device must be installed in a control cabinet.
-

- ▶ Ensure that the output contacts have sufficient protective circuitry for capacitive and inductive loads.
  - ▶ Follow the specifications in the general technical data.
- 

**Note**

More detailed information can be found in the → **Technical data** section.

---

**WARNING**

**Electric shock – dangerous voltage!** During operation, switching devices conduct dangerous voltages.

- ▶ Never remove protective covers from electrical switching devices during operation.
- 

- ▶ Replace the device the first time a fault occurs.
- 



- ▶ Dispose of the device in accordance with nationally applicable environmental regulations.
- 

## 2.5.1 Retrofitting and conversion

- Unauthorized conversion voids any warranty. This can cause hazards that can lead to severe or even fatal injury.

## 2.5.2 Basic safety regulations

The safety regulations listed below must always be complied with. In the event that these safety regulations are not complied with or the device is used improperly, **DINA Elektronik GmbH** accepts no liability for any resulting injury or damage.

- The product described here has been developed to perform safety-related functions as part of an entire system.
- The entire system is made up of sensors, analysis units, reporting units and safe switch-off concepts.
- It is the responsibility of the manufacturer of a system or machine to validate the correct overall function.
- The manufacturer of the system is obligated to check and document the efficacy of the implemented safety concept within the entire system. This documentation must be produced again every time the safety concept or safety parameters are modified.
- Maintain a network connection only as long as necessary.
- The manufacturer's specifications for the system or machine with regard to maintenance intervals must be complied with.

- **DINA Elektronik GmbH** is not able to make any guarantees regarding the properties of an overall system not designed by the company.
- **DINA Elektronik GmbH** accepts no liability for any recommendations given or implied in the following description.
- No new guarantee, warranty or liability claims that go beyond **DINA Elektronik GmbH's** general delivery conditions can be derived from the following description.
- To prevent EMC disturbances, the physical environmental and operating conditions where the product is installed must correspond to the EMC section of DIN EN 602041.
- If contact outputs are used, the safety function must be requested at least once per month for Performance Level (e) and once per year for Performance Level (d).

## 2.6 Working on live parts

---



### **WARNING**



**Electric shock – dangerous voltage!** Touching live components can cause severe or even fatal injury, depending on circumstances, as a result of an electric shock.

- ▶ Never assume that a circuit is dead.
  - ▶ Always check circuits as a safety precaution! Components being worked on may only be live if this is absolutely necessary and stipulated.
  - ▶ Accident prevention regulations (e.g. VBG4 and VDE 105) must be observed during all work.
  - ▶ Only use suitable, intact tools and measuring equipment.
-

### 3 EC declaration of conformity



## Original EG-Konformitätserklärung

(gemäß der Richtlinie 2006/42/EG, Anhang II, 1A)

## Original EC-Declaration of Conformity

(according to Directive 2006/42 / EC, Annex II, 1A)

DINA Elektronik GmbH  
Esslinger Str. 84  
72649 Wolfschlugen  
Deutschland

Wir erklären, dass das folgende Produkt allen einschlägigen Bestimmungen der Richtlinie 2006/42/EG entspricht.

We declare, that the following product fulfils all the relevant provisions of Directive 2006/42/EC.

Produkt/ Product	Funktion/ Function
SAFEONE DS, SAFEONE XS, SAFEONE XD Sicherheitsschaltgerät Safety device ID-No.: 34DS21, 34XS01, 34XD01	Kompaktes, konfigurierbares Sicherheitsschaltgerät zur sicheren Maschinenüberwachung Compact, configurable safety module for safe machine monitoring .

#### Weitere EU-Richtlinien/ Further EC- directives

2014/30/EU EMV-Richtlinie/ EMC-Directive  
2011/65/EU RoHS Richtlinie/ RoHS-Directive

Benannte Stelle/ Notified Body	EG Baumusterprüfbescheinigung/ EC Type-Examination certificate
DGUV Test Prüf- und Zertifizierungsstelle, Elektrotechnik Fachbereich Energie Textil Elektro Medienerzeugnisse Gustav-Heinemann-Ufer 130 D-50968 Köln  (Kenn-Nr. 0340)	Reg.-Nr./No.: ET 22049

#### Bevollmächtigter für die Zusammenstellung der technischen Unterlagen/ Authorized representative for the compilation of the technical documents.

DINA Elektronik GmbH  
Esslinger Str. 84  
72649 Wolfschlugen  
Deutschland

Wolfschlugen, 26.01.2023



Markus Henzler, Entwicklung

## 4 Product description

The SAFEONE XS safety switchgear is a compact, configurable module for safe machine monitoring. The device has

- safe digital inputs
- analog inputs (0-10V)
- overload and short-circuit-proof semiconductor outputs
- contact outputs

The inputs are intended for the connection of various safety devices and offer a wide range of safety functions. With the configuration software GO:BEYOND®.logic you can implement various security functions, such as

- Emergency stop monitoring
- Protective door monitoring
- Operating mode selector switch
- Monitoring of non-contact protective devices

### 4.1 Connections

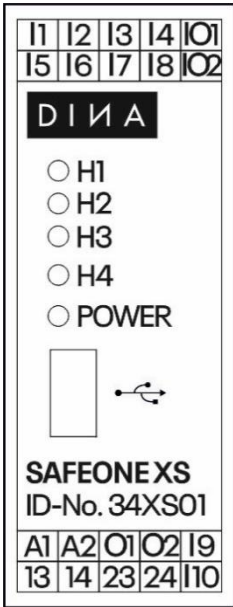
 <p>The diagram shows a terminal block with two rows of terminals. The top row contains I1, I2, I3, I4, O1. The bottom row contains I5, I6, I7, I8, O2. Below these are four status LEDs labeled H1, H2, H3, H4, and a POWER LED. A USB port is also shown. The device is labeled SAFEONE XS ID-No. 34XS01. At the bottom, there are two rows of terminals: A1, A2, O1, O2, I9 in the first row, and I13, I14, I23, I24, I10 in the second row.</p>	I1 to I8	Configurable as <ul style="list-style-type: none"> <li>▪ digital inputs</li> </ul> or <ul style="list-style-type: none"> <li>• analog inputs (0 – 10V)</li> </ul>
	I9, I10	Digital inputs
	IO1, IO2	Digital inputs or outputs
	A1	Power supply +24 V DC
	A2	Power supply 0V
	O1, O2	Safety semiconductor outputs
	I13/I14, I23/I24	Enabling contacts
	USB-Port	Mini-USB
	LED H1 to H4	Configurable status displays
	LED POWER	Power on/off, configurable

## 4.2 Block diagram

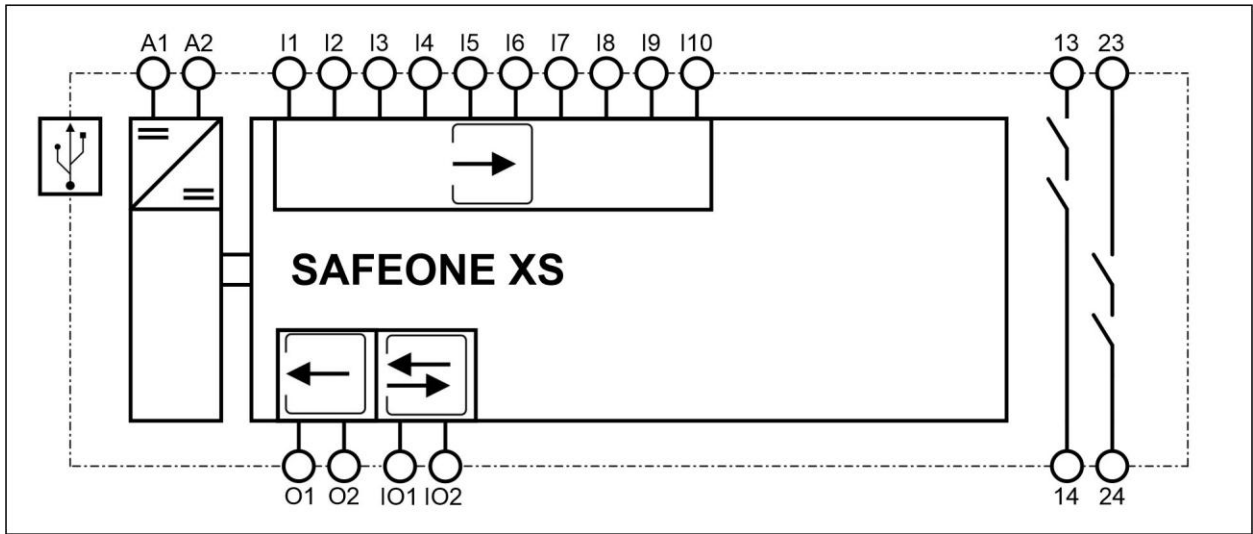

Inputs



Outputs



USB



Inputs/outputs

## 4.3 Diagnostics and switching status displays

The module has an LED display that can be configured for specific applications using the GO:BEYOND®.logic configuration software.



### Note:

During the transfer, the POWER LED lights red and the safety relay is in a safe state.

After a successful self-test, the device is ready for operation. The POWER LED flashes green (default).

## 5 Example of application

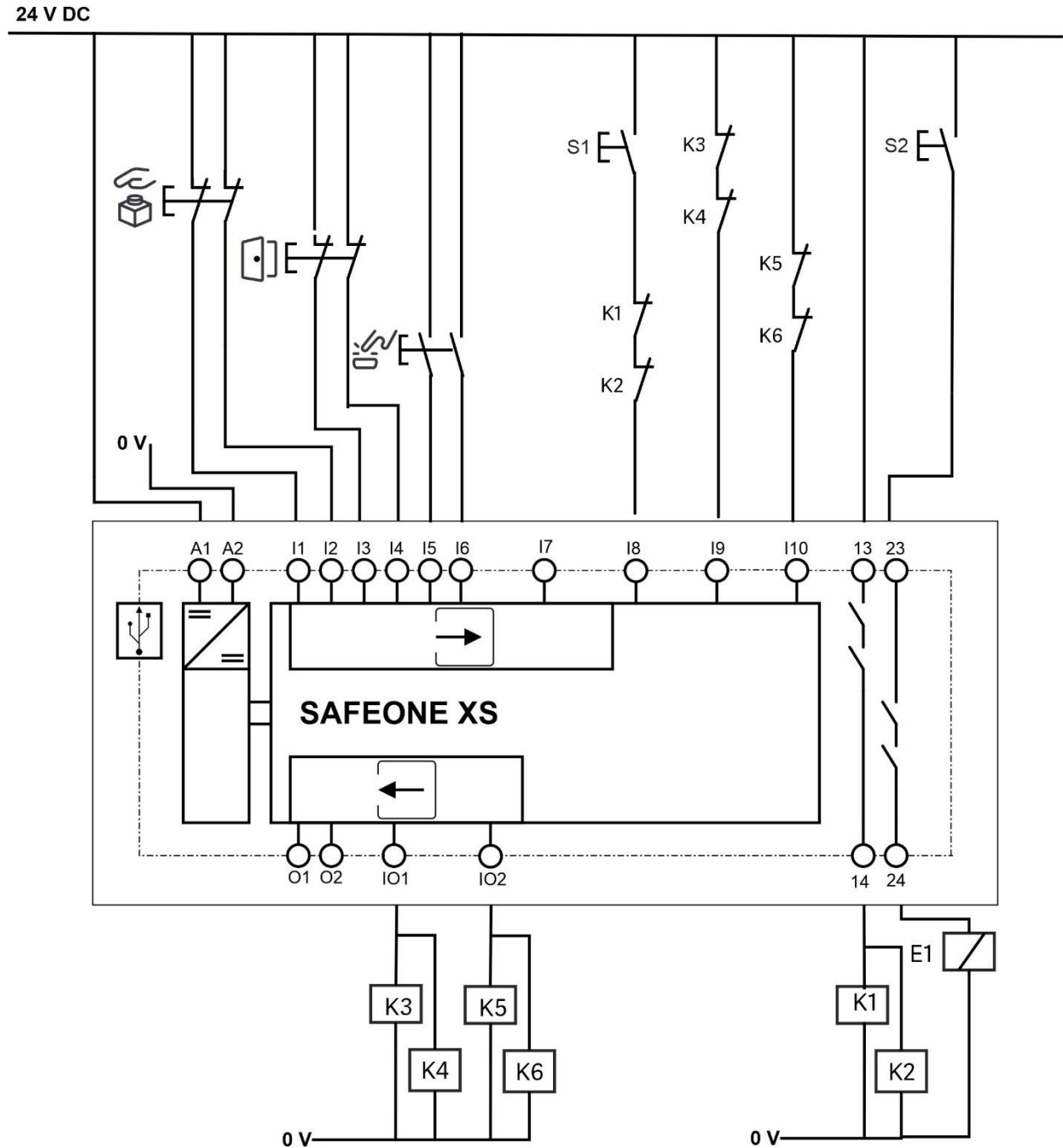

**Legend:**

- |   |                       |    |                                      |
|---|-----------------------|----|--------------------------------------|
|  | Emergency stop switch | S1 | Acknowledgment button emergency stop |
|  | Protective door       | S2 | Safety door release                  |
|  | Acknowledgment button | E1 | Safety door guard locking            |

## 6 Order information

Description	Product	ID-No.
Compact, configurable safety switching device for safe machine monitoring	SAFEONE XS	34XS01

## 7 Technical data

### 7.1 Supply

Operating voltage $U_B$	24 V DC (-15/+10%)
Current consumption at 24V	50 mA
Power consumption at A1/A2	1.2 W

### 7.2 Digital inputs



Inputs	10 safety inputs I1 – I10
Input voltage range	24 V DC (-15/+10%)
Current consumption	Typ. 4mA (at $U_B$ )
Input voltage range „0“-signal	0...5 V DC
Input voltage range „1“-signal	15 V DC...30 V DC

### 7.3 Analog inputs

Inputs	8 analog inputs I1 – I8
Input voltage	0 to 10V
Accuracy of analog inputs	± 3% of the end value
Input impedance of analog inputs	> 5 K $\Omega$

### 7.4 Transistor outputs

Outputs	O1, O2	IO1, IO2
---------	--------	----------

Output type	 PNP	 PNP
Voltage	24 V	24 V
Max. switching current	1 A	0.5 A
Max. total switching current	2 A	1 A
Min. switching current	1 mA	1 mA

## 7.5 Contact outputs

Outputs	13/14, 23/24
Contact material	Ag alloy
Output guidance, performance level	 , PLd
Minimum switching current	10 mA
Switching capacity in accordance with IEC 60947-5-1	DC13: 1A/30V DC
Mechanical service life	5 x 10 <sup>7</sup> switching cycles
Contact fuse	3 A gL/gG
Typical response time	10 ms / 10 ms

## 7.6 General data

Type of protection (housing and terminals)	IP 20
Type of protection (place of installation)	min. IP 54
Clearance and creepage distances between circuits	In accordance with DIN EN 50178
Rated insulation voltage	50V AC
Rated surge voltage/insulation	0.8 kV
Degree of contamination	2
Overvoltage category	III

Housing material	Polyamide (PA), not reinforced
------------------	--------------------------------

### 7.7 Connection data

Terminals	Push-in, pluggable
Conductor cross section	0.25 – 1.5mm <sup>2</sup>
AWG conductor cross section	24...16
Conductor type	Flexible with end sleeves
Stripping length	9 mm

### 7.8 Environmental conditions

Operating temperature	-10 °C to +55 °C
Storage temperature	-40 °C to +85 °C
Attitude of place of use	< 2000 m above sea level
Shock resistance	11g
Vibration	2g

### 7.9 Dimensions

B x H x T	22,5 x 114 x 111 mm (0.886 x 4.488 x 4.370 in)
Size of DIN rail	35,0 mm (1.378 in)

### 7.10 Safety-related parameters in accordance with DIN EN ISO 13849-1:2016-06

Category	3
Performance Level	d
MTTFd [a]	100

## 7.11 Safety-related parameters in accordance with EN ISO 61508-High Demand

HFT	1
SIL	2
PFHd [1/h]	4,29E-08 (1A DC13; 5 cycles/h)
Demand rate	< 12 months
Proof-Test-Interval	20 years

## 7.12 Contact life

Electrical service life of the output contacts in accordance with DIN EN 60947-5-1/ Annex C.3

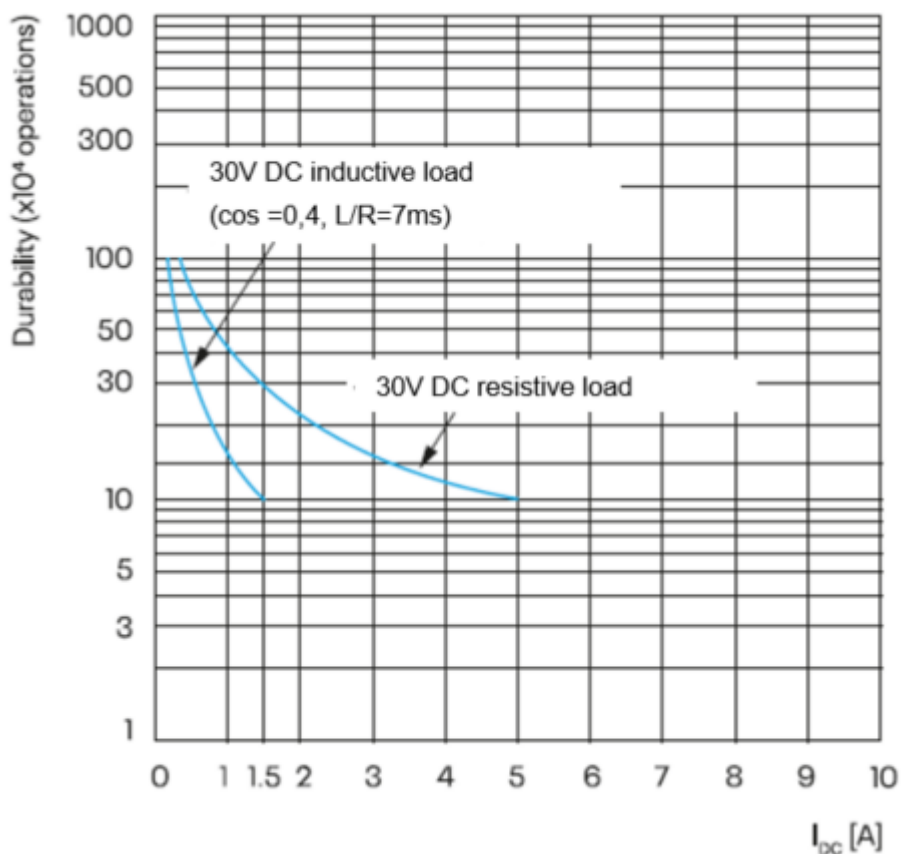

## 8 Installation and removal

### 8.1 Installing a module

#### 8.1.1 Overview

- (A) 70-75 mm (2,756-2,953 in)
- (1) Top hat rail
- (2) Locking slider
- (3) Cable duct

#### Procedure

- ▶ Hook the module onto the top hat rail (1) and press it downward.
- ▶ The locking slider (2) engages under the top hat rail.

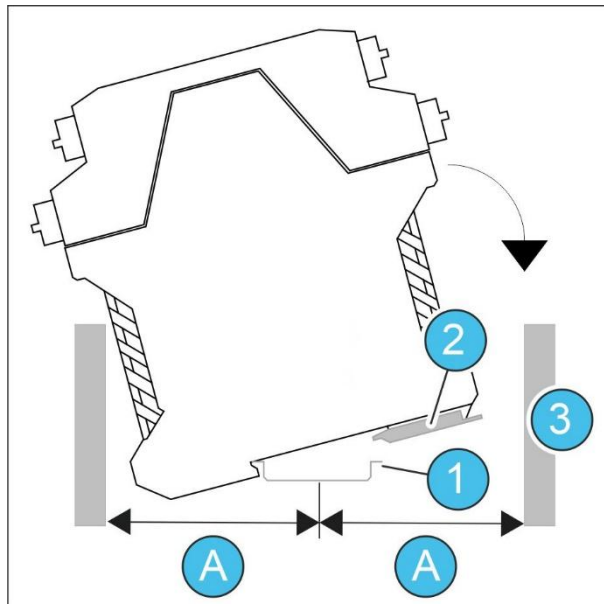

### 8.2 Removing a module

#### Procedure

- ▶ Use a screwdriver (1) to move the locking slider away from the module.
- ▶ Move the module upward and remove it from the rail.

