

# Kabeladapter/ Cable adapter

Betriebsanleitung  
Instruction manual

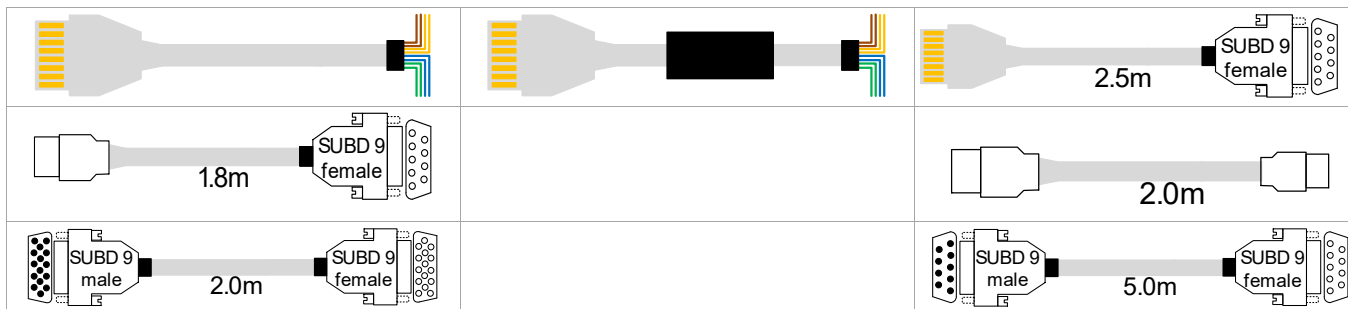
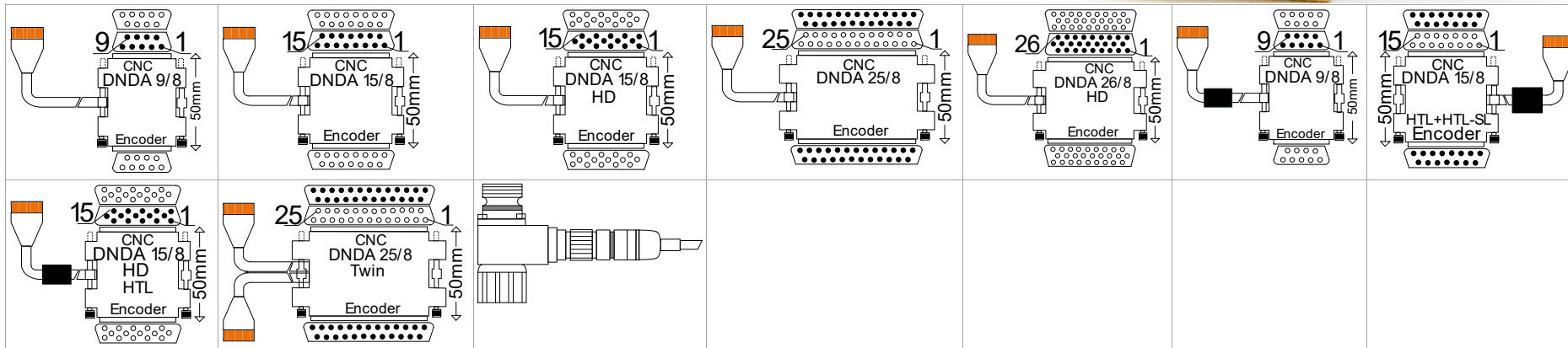

Diese Betriebsanleitung ist gültig für:

This manual is valid for:

**Bezeichnung**  
**Description**

Kabeladapter  
Cable adapter

Version: 04.11.2025



**DINA Elektronik GmbH**  
Esslinger Str. 84  
D-72649 Wolfschlugen

Phone +49 7022 95170  
info@dina.de  
www.dina.de

---

## Inhaltsverzeichnis/content

		DNDA 15/8/ RJ45 ▶ Pin 1/ F	13
		DNDA 15/8/ RJ45 ▶ Pin 15/ M	14
Bestimmungsgemäße und bestimmungswidrige Verwendung	5	DNDA 15/8 HTL SL ▶ Pin 15/ M	14
Sicherheitsbestimmungen	5	DNDA 15/8/ TWIN ▶ Pin 15/ F	15
Intended use and improper use	5	DNDA 15/8/ RJ45 ▶ Pin 1/ M	15
Safety regulations	5	DNDA 15/8 HTL-SL ▶ Pin 1/ M	16
Anschlussbelegungen/pin assignments	6	DNDA 15/15/ SUBD ▶ Pin 1/ M	16
DNDA 9/8/ RJ45 ▶ Pin 9/ F	6	DNDA 15/8	17
DNDA 9/Kabel ▶ Pin 9 / F	7	DNDA 15/8/15	17
DNDA 9/8 HTL ▶ Pin 9/ F	7	DNDA 15/8 HD/ RJ45 ▶ Pin 15/ F	17
DNDA 9/8/ RJ45 ▶ Pin 1/ F	8	DNDA 15/8 HD RJ45 ZENT ▶ F	18
DNDA 9/8/ RJ45 ▶ Pin 9/ F	8	DNDA 15/8 HD HTL SL ▶ Pin 15/ F	19
DNDA 9/8/ RJ45 ▶ Pin 9/ M	9	DNDA 15/8 HD TWIN ▶ Pin 15/ F	19
DNDA 9/8 LANG ▶ F	9	DNDA 15/3+2 HD/ DIN/ T ▶ Pin 15/ M	20
DNDA 12/8 611D	10	DNDA 15/ T/ HD/ T ▶ Pin 1/ F	20
DNDA 17/8 POSMO	10	DNDA 25/ 8/ RJ45 ▶ Pin 25/ F	20
DNDA 15/8/ RJ45 ▶ Pin 15/ F	10	DNDA 25/ 8/ RJ45 Pin ▶ 25/ M	21
DNDA 15/8 HTL ▶ Pin 15/ F	12	DNDA 25/8 K ▶ Pin 25/ M	21
DNDA 15/8/ TWIN ▶ Pin 15/ F	12	DNDA 25/8 T ▶ Pin 25/ M	22

<b>DNDA 25/ 2/ T ▶ Pin 25/ M</b>	<b>22</b>	<b>Abmessungen/Dimensions</b>	<b>30</b>
<b>DNDA 25/8 TWIN ▶ Pin 25/ M</b>	<b>22</b>	<b>Technische Daten/Technical data</b>	<b>31</b>
<b>DNDA 25/3 DIN-R HTL/ DIN ▶ Pin 25/ M</b>	<b>23</b>		
<b>DNDA 25/7 TBS ▶ Pin 25/ M</b>	<b>23</b>		
<b>DNDA 25/ REF ▶ Pin 25/ M</b>	<b>23</b>		
<b>DNDA 25/8/ RJ45 ▶ Pin 1/ M</b>	<b>24</b>		
<b>DNDA 25/8/ RJ45 ▶ Pin 1/ F</b>	<b>24</b>		
<b>DNDA 25/8 T ▶ Pin 1/ M</b>	<b>25</b>		
<b>DNDA 26/8/HD/RJ45 ▶ Pin 26/F</b>	<b>25</b>		
<b>DNDA 26/26/HD/HD ▶ Pin 1/ F</b>	<b>26</b>		
<b>D-SUB Komponenten/ D-SUB components</b>	<b>27</b>		
<b>Anschlusskabel/ Connection cable</b>	<b>27</b>		
<b>DNRJ 45</b>	<b>27</b>		
<b>RJ45-SUBD9</b>	<b>28</b>		
<b>RJ45 – RJ45</b>	<b>28</b>		
<b>USB-SUBD 9</b>	<b>28</b>		
<b>USB-USB MIN</b>	<b>28</b>		
<b>COM-COM</b>	<b>29</b>		
<b>SUBD 15/ HD–SUD 15/ HD</b>	<b>29</b>		

## Bestimmungsgemäße und bestimmungswidrige Verwendung

Die Kabeladapter DNDA und DNRJ 45 sind eine Signalverbindung zwischen dem Messsystem einer Achse und DINA Sicherheitsschaltgeräten zur Überwachung des Stillstands und anderen Betriebsarten.

Beide Verbindungskabel können eingesetzt werden mit DNDS, SAFELINE und SL VARIO.

Sie sind lieferbar in den verschiedensten Varianten und Kabellängen passend zu jedem Antriebssystem.

Jeder andere oder darüberhinausgehende Gebrauch gilt als nicht bestimmungsgemäß.

Wird das Produkt:

- nicht bestimmungsgemäß verwendet,
- falsch gewartet oder
- falsch bedient,

übernimmt der Hersteller für auftretende Schäden keine Verantwortung. Das Risiko trägt in diesem Fall alleinig der Benutzer.

## Sicherheitsbestimmungen

- ▶ Durch eigenmächtige Umbauten erlischt jegliche Gewährleistung. Es können dadurch Gefahren entstehen, die zu schweren Verletzungen oder sogar zum Tode führen.
- ▶ Wechseln Sie das Produkt nach dem ersten Fehlerfall aus.
- ▶ Entsorgen Sie das Gerät entsprechend den national gültigen Umweltvorschriften.



## Intended use and improper use

The cable adaptors DNDA and DNRJ 45 are a signal connection between the measuring system of an axle and the DINA safety systems to monitor the standstill and others function modes.

Both connection cable can be used with DNDS, SAFELINE and SL VARIO. They are deliverable in different variants and cable length suitable to every drive measuring system.

Any other form of use is regarded as improper use.

If the product is

- not used as intended,
- improperly maintained or
- incorrectly operated,

the manufacturer will not assume any liability for any damage that results. In this case, the risk shall be borne exclusively by the user.

## Safety regulations

- ▶ Unauthorized conversion voids any warranty. This can cause hazards that can lead to severe or even fatal injury.
- ▶ Replace the device the first time a fault occurs.
- ▶ Dispose of the device in accordance with nationally applicable environmental regulations.



## Anschlussbelegungen/pin assignments

Symbol innerhalb der Überschrift			Symbol inside the title		
▶	F	M	▶	F	M
RJ45 Kabel an der Seite von Pin 1, 9, 15, 25, 26	Buchse	Stecker	RJ45 Cable at the side of pin 1, 9, 15, 25, 26	Female	Male

### DNDA 9/8/ RJ45 ▶ Pin 9/ F

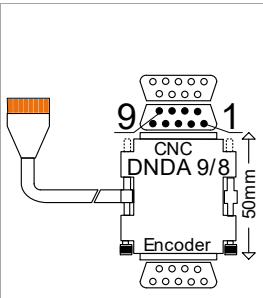
		X8-Lenze	LANG	Indel-SAC2	C99/D	C-88	NTI X12	MTU-1	Lust CDD/R	MD84	SEW-X15Enc	IEF X4 E	SRS50M3
	ID-No.	93LE21	93LE22	91PS23	91ZE21	91EC21	91NT21	91MT21	91LU09	93SM21	92RE02	92IE21	93SR21
<b>UB</b>	4	--	9	5	1	1	9	--	4	--	2	--	
<b>0V</b>	5	2	8	6	2	5	6	4	5	5	3	9	
<b>A</b>	3	6	2	2	3	6	4	1	1	1	1	1	
<b>A/</b>	2	1	3	7	5	2	5	2	2	6	6	2	
<b>B</b>	1	8	4	3	4	7	1	3	6	2	9	3	
<b>B/</b>	9	3	5	8	6	3	2	8	7	7	5	4	

	IEF X2A R	AX2000	Indel/R	AMK-X130	AC122	Lenze/R	SM-SD2 X8	Ferro con-2R	X15R-SEW	LTI
ID-No.	91IE21	91AX21	91ID21	91AM21	92BR21	94LE21	91SM21	91FC22	91RE41	91LT01
<b>UB</b>	--	--	--	--	--	--	--	--	--	--
<b>0V</b>	--	--	--	--	--	3	--	--	--	--
<b>A</b>	1	8	4	3	4	6	1	4	1	1
<b>A/</b>	6	4	8	4	8	7	6	5	6	2
<b>B</b>	2	7	3	5	3	4	4	3	2	3
<b>B/</b>	7	3	7	6	7	5	9	2	7	8
<b>R</b>	4	9	5	7	5	1	7	1	3	6
<b>R/</b>	9	5	9	8	9	2	3	9	8	7

### DNDA 9/Kabel ► Pin 9 / F

	<b>C99/D</b>	
	<b>ID-No.: 91ZE51</b>	
	<b>UB</b>	5
	<b>0V</b>	6
	<b>A</b>	2
	<b>A/</b>	7
	<b>B</b>	3
	<b>B/</b>	8

### DNDA 9/8 HTL ► Pin 9/ F

	<b>DNDA 9/8 Lenze/R1</b>	Schirmung	E: Schirmung		Schirmung
<b>ID-No.</b>	<b>95LE21</b>	<b>SUBD9 --&gt;RB</b>	<b>Referenzbildung RB</b>	<b>RB --&gt; RJ45-Kabel</b>	
	--	<b>UB</b>	--	9	<b>UB</b>
	--	<b>0V</b>	--	10	<b>0V</b>
	6	<b>A</b>	1	1	<b>A</b>
	7	<b>A/</b>	2	2	<b>A/</b>
	4	<b>B</b>	4	4	<b>B</b>
	5	<b>B/</b>	3	3	<b>B/</b>
	1	<b>R</b>	5	8	<b>R</b>
	2	<b>R/</b>	6	7	<b>R/</b>

95LE21: (1) 40cm (2) 300cm

	<b>BR-X6-HTL-SL</b>	<b>CT-SK3-HTL</b>
<b>ID-No.</b>	<b>91BR01</b>	<b>92CO72</b>
<b>UB</b>	--	--
<b>0V</b>	9	1
<b>A</b>	1	3
<b>A/</b>	2	4
<b>B</b>	3	5
<b>B/</b>	4	6

91BR01: (1) 35cm (2) 65cm

### DNDA 9/8/ RJ45 ► Pin 1/ F

	AC122 E	Jet Move X61 Hifa	140R	Jet MoveX61 R
ID-No.	92BE21	93JM21	91SL21	91JM21
<b>UB</b>		5	--	--
<b>0V</b>		4	5	--
<b>A</b>	4	7	7	7
<b>A/</b>	8	2	3	2
<b>B</b>	3	8	8	8
<b>B/</b>	7	3	4	3
<b>R</b>			9	1
<b>R/</b>			5	6

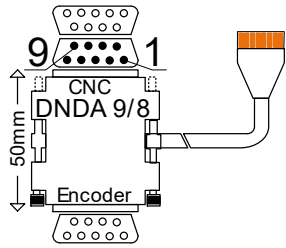

### DNDA 9/8/ RJ45 ► Pin 9/ F

	Jet Move X61 Hifa	140R	Jet MoveX61 R
ID-No.	93JM21	91SL21	91JM21
<b>UB</b>	5	--	--
<b>0V</b>	4	5	--
<b>A</b>	7	7	7
<b>A/</b>	2	3	2
<b>B</b>	8	8	8
<b>B/</b>	3	4	3
<b>R</b>	--	9	1
<b>R/</b>	--	5	6

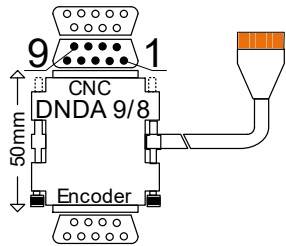

### DNDA 9/8/ RJ45 ► Pin 9/ M

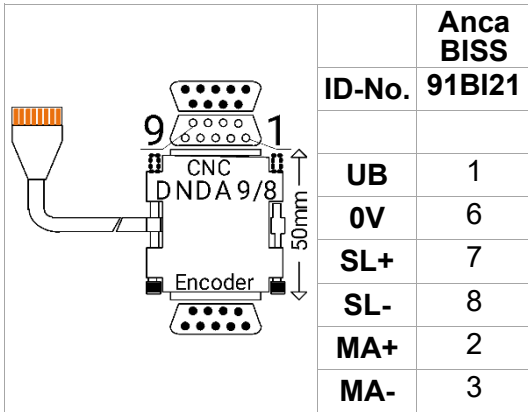

### DNDA 9/8 LANG ► F

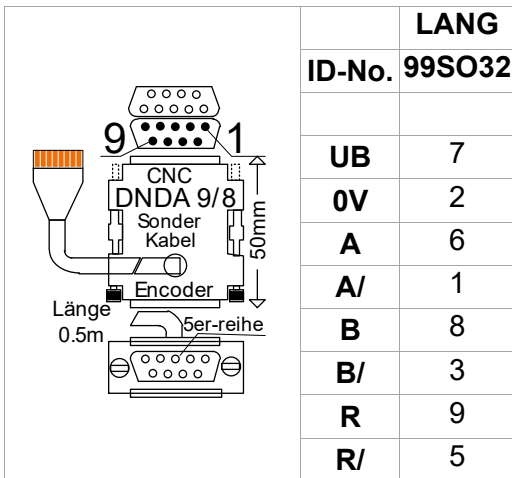

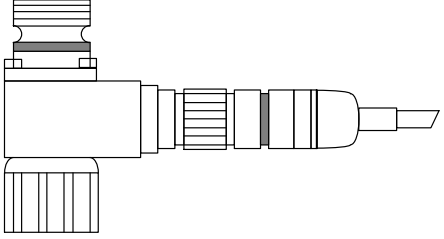
		<b>DNDA 12/8 611D</b>	<b>DNDA 17/8 POSMO</b>
		12/8 T-stück 2,5m Lumberg	17/8 T-Stück 3,0 m Phoenix
		<b>M23-T</b>	<b>POSMO</b>
	<b>ID-No.</b>	<b>99SI29</b>	<b>99SI30</b>
	<b>UB</b>	--	16
	<b>0V</b>	10	15
	<b>A</b>	5	1
	<b>A/</b>	6	2
	<b>B</b>	8	11
<b>B/</b>	1	12	

Stecker Pins sind mit den Buchsen-Pins eins zu eins zu verbinden.  
Male pin are with female pin one to one connected.

### DNDA 15/8/ RJ45 ► Pin 15/ F

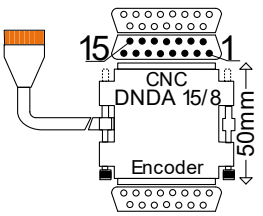
		<b>AMK-RES</b>	<b>SITRA</b>	<b>AC120/124</b>	<b>AC120/124</b>	<b>AMK</b>	<b>MHD/G</b>	<b>ALBR</b>	<b>Stoeber X4</b>	<b>FGB-1</b>	<b>BM-5V</b>
	<b>ID-No.</b>	<b>92AM22</b>	<b>91ST22</b>	<b>93AT22</b>	<b>93AT23 *)</b>	<b>91AM22</b>	<b>91IN22</b>	<b>91AB22</b>	<b>92ST22</b>	<b>91FG22</b>	<b>94BM22</b>
	<b>UB</b>	--	4	4	--	7	12	9	4	2	2
	<b>0V</b>	8	5	2	--	8	4	12	2	3	1
	<b>A</b>	10	7	1	1	4	2	1	6	1	8
	<b>A/</b>	9	13	9	9	3	9	--	11	9	7
	<b>B</b>	12	15	3	3	6	3	3	1	12	5
	<b>B/</b>	11	6	11	11	5	10	--	9	5	9

\*) Achtung: Bei der ID-No 93AT23 ist der Schirm nicht mit dem SUB D Gehäuse verbunden

	611D-B	MCB-3	Kit R	INFOT	MC S-7/E-8	B+R PNM	B+R AC120 PNM	MOVIAXIS	NTI X13
ID-No.	91EL22	93MC22	92KI22	92PI22	94MC22	95BR22	93BR22	91MO22	91NT22
UB	1	15	8	12	9	--	--	--	1
0V	2	10	9	10	1	2	2	--	5
A	3	3	14	1	5	11	1	2	9
A/	4	9	6	9	13	3	9	10	2
B	6	6	13	3	6	9	3	1	10
B/	7	11	5	11	14	1	11	9	3

	AC121	SEW X15	Indra DYN	BMVR1	DARC	SMC30	AC121B	DEF 01.1M	Stoeber X4TTL
ID-No.	94AT22	91RE01	99IN22	91BN22	91DA22	91SM22	95AT22 <sup>(2)</sup>	92IN22	92TL22
UB	4	15	11	2	12	4	4	12	4
0V	2	8	4	1	6	7	2	10	2
A	1	2	2	8	5	15	1	5	8
A/	9	10	3	7	3	14	9	6	15
B	3	1	5	5	8	13	3	8	5
B/	11	9	6	9	4	12	11	1	13

	BM4 R	MCR-6	MDLA R	SEW X13R
ID-No.	93BM22	92MC22	93MD22	92TS22
UB	--	--	--	--
0V	--	--	--	--
A	7	3	5	1
A/	8	11	12	9
B	9	2	6	2
B/	5	10	13	10
R	--	4	14	5
R/	--	12	7	13

**DNDA 15/8 HTL ▶ Pin 15/ F**

		MDS5-HTL-SL	
		ID-No.	92MD22
	<b>UB</b>	--	
	<b>0V</b>	2	
	<b>A</b>	6	
	<b>A/</b>	11	
	<b>B</b>	1	
	<b>B/</b>	9	

**DNDA 15/8/ TWIN ▶ Pin 15/ F**

		SEWTWIN X13R	
		ID-No.	91TS22
	<b>A</b>	1	
	<b>A/</b>	9	
	<b>B</b>	2	
	<b>B/</b>	10	
	<b>R</b>	5	
	<b>R/</b>	13	

		ID-No.	91MV22			
			SUBD 1-8 RJ 1-8/ System1	SUBD 12-15 RJ 12-15/ System2		
	<b>0V</b>	1	4	---	---	
	<b>UB</b>	2	5	---	---	
	<b>C+</b>	3	1	---	---	
	<b>C-</b>	4	2	---	---	
	<b>D+</b>	5	3	12	1	
	<b>D-</b>	6	6	13	2	
	<b>S</b>	7	7	14	7	
	<b>VM</b>	8	8	15	8	

## DNDA 15/8/ RJ45 ► Pin 1/ F

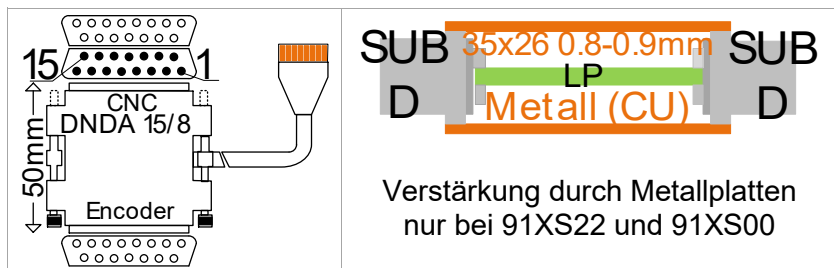

Verstärkung durch Metallplatten  
nur bei 91XS22 und 91XS00

	MHD/GE	AC120E	AC121E	TS2620/40	Indra dyn2	ANCA 5DX	ANCA AMD5000	X4S	S300	PDMS-A 15/8	STEC S2E
ID-No.	92JN22	93BE22	94BE22	93ST22	99PS22	91AN22	91AN23	91XS22	91DH22	91SE22	
<b>UB</b>	12	4	4	--	--	--	--	4	4	10	
<b>0V</b>	4	2	2	7	4	15	15	2	2	3	
<b>A</b>	2	1	1	3	2	14	14	11	11	14	
<b>A/</b>	9	9	9	4	3	7	7	3	3	7	
<b>B</b>	3	3	3	1	5	10	10	9	9	15	
<b>B/</b>	10	11	11	2	6	2	2	1	1	8	

AC121E: 8+10 Stift entfernt/ male pin removed	X4S: 1, 3, 6, 7, 9, 10, 11, 14 Stift entfernt/ male pin removed	AC123E: mit Gleitverriegelung/ with slide locks	ANCA 5Dx: mit Schrauben/ with screws
--	--	--	---

KOSME	
ID-No.	99SO31
<b>UB</b>	2
<b>0V</b>	--
<b>A</b>	--
<b>A/</b>	1
<b>B</b>	--
<b>B/</b>	11
<b>R</b>	9
<b>R/</b>	3

### DNDA 15/8/ RJ45 ► Pin 15/ M

	Siem ADI4	DAE1.1	E-PMC2	Num MdlA100	DSV-X3	B03315	KEB	MC S-7/E-8
<b>ID-No.:</b>	<b>91SA22</b>	<b>94IN22</b>	<b>93SO22</b>	<b>94NU21</b>	<b>92PA23</b>	<b>94SS22</b>	<b>91KB22</b>	<b>94MC22</b>
								
<b>UB</b>	4	12	14	--	3	7	12	9
<b>0V</b>	7	10	5	--	4	15	10	1
<b>A</b>	15	5	2	12	1	1	5	5
<b>A/</b>	14	6	1	5	2	2	6	13
<b>B</b>	13	8	4	13	5	4	8	6
<b>B/</b>	12	1	3	6	6	5	1	14

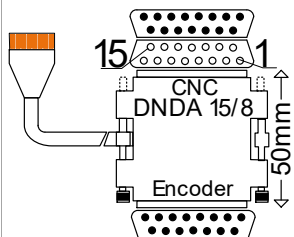

	SIMO 611D	FM-NC	SIN 800	WF723C	DLF01.1M-A	D150	DZF 03.1M	EP20
<b>ID-No.</b>	<b>91SI22</b>	<b>98SI22</b>	<b>96SI22</b>	<b>98SO22</b>	<b>96IN22</b>	<b>91SO22</b>	<b>93IN22</b>	<b>92EP22</b>
<b>UB</b>	1	4	14	4	12	4	12	--
<b>0V</b>	2	9	11	7	10	5	10	15
<b>A</b>	3	15	1	15	7	8	7	2
<b>A/</b>	4	14	9	14	8	7	15	1
<b>B</b>	6	13	10	13	6	13	13	3
<b>B/</b>	7	12	3	12	5	14	14	4

### DNDA 15/8 HTL SL ► Pin 15/ M

	611D-HTL-SL	BRATZ-HTL	SMC30-HTL
<b>ID-No.</b>	<b>92SK20</b>	<b>91BZ02</b>	<b>92SC22</b>
<b>UB</b>	--	12	4
<b>0V</b>	2	10	7
<b>A</b>	3	5	15
<b>A/</b>	4	6	14
<b>B</b>	6	8	13
<b>B/</b>	7	1	12

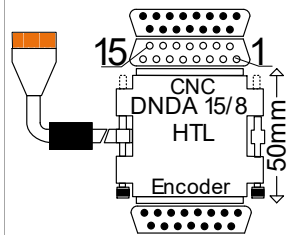

### DNDA 15/8/ TWIN ► Pin 15/ F

	S300 TWIN R	S300 TWIN L
<b>ID-No.</b>	<b>91TR22</b>	<b>91TL22</b>
<b>UB</b>	4	4
<b>0V</b>	2	2
<b>A</b>	11	9
<b>A/</b>	3	1
<b>B</b>	9	11
<b>B/</b>	1	3

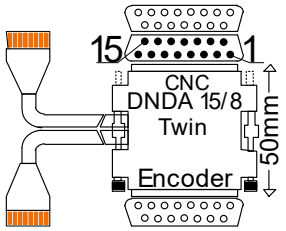

### DNDA 15/8/ RJ45 ► Pin 1/ M

	SIMO E 611D	E CM	MC6	AX5-R	MKD
<b>ID-No.</b>	<b>92SI22</b>	<b>95CM12</b>	<b>91MC12</b>	<b>92AX42</b>	<b>97IN25</b>
<b>UB</b>	1	1	--	--	--
<b>0V</b>	2	2	12	2	--
<b>A</b>	3	3	4	11	3
<b>A/</b>	4	4	11	4	4
<b>B</b>	6	6	3	10	6
<b>B/</b>	7	7	10	3	8
<b>R</b>	--	--	--	12	5
<b>R/</b>	--	--	--	5	7

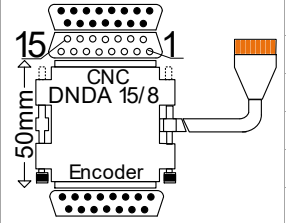

### DNDA 15/8 HTL-SL ▶ Pin 1/ M

<p>Diagram of DNDA 15/8 HTL-SL Encoder. It shows a 15-pin connector on the left and an 8-pin connector on the right. The encoder is labeled 'CNC DNDA 15/8 HTL+HTL-SL Encoder'. Dimensions include a 50mm height and pin numbers 15 and 1.</p>	<b>AC123 DS-HTL</b>	
	<b>ID-No.</b>	<b>97BE22</b>
	<b>UB</b>	13
	<b>0V</b>	12
	<b>A</b>	1
	<b>A/</b>	2
	<b>B</b>	3
<b>B/</b>	4	

### DNDA 15/15/ SUBD ▶ Pin 1/ M

<p>Diagram of DNDA 15/15/ SUBD Encoder. It shows a 15-pin connector on the left and a 15-pin SUBD connector on the right. The encoder is labeled 'CNC DNDA 15/15 Encoder'. Dimensions include a 50mm height and pin numbers 15 and 1.</p>	<b>AC120</b>	<b>X-OUT</b>	<b>GM</b>	<b>X-OUT</b>	<b>SIMO 611D</b>	<b>X-OUT</b>	
	<b>ID-No.</b>	<b>91BE26</b>		<b>96GM26</b>		<b>91SI26</b>	
	<b>UB</b>	4	1	13	1	1	1
	<b>0V</b>	2	2	11	2	2	2
	<b>A</b>	1	3	9	3	3	3
	<b>A/</b>	9	4	14	4	4	4
	<b>B</b>	3	6	1	6	6	6
<b>B/</b>	11	7	4	7	7	7	

## DNDA 15/8

Hutschienenmontage DIN rail mounting		H DMC H SIN	
ID-No.	95SI22	95SI23	
<b>UB</b>	13	14	
<b>0V</b>	11	11	
<b>A</b>	9	1	
<b>A/</b>	14	9	
<b>B</b>	1	10	
<b>B/</b>	4	3	

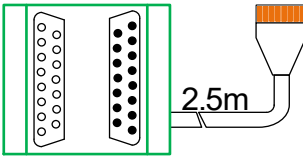

## DNDA 15/8/15

Hutschienenmontage DIN rail mounting		AC120/124	
ID-No.	99BE22		
<b>UB</b>	4		
<b>0V</b>	2		
<b>A</b>	1		
<b>A/</b>	9		
<b>B</b>	3		
<b>B/</b>	11		

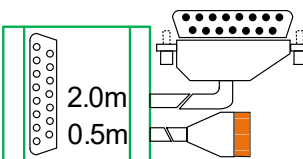

## DNDA 15/8 HD/ RJ45 ► Pin 15/ F

		Compax X13R	AMD 2000	SCARA	Kabel handelsüblich	TRIA PNM
ID-No.	93CO22	91AN12	91AN13			91TA22
<b>UB</b>	--	--	--		<b>UB</b>	--
<b>0V</b>	--	15	15		<b>0V</b>	6
<b>A</b>	8	2	7		<b>A</b>	2
<b>A/</b>	7	1	8		<b>A/</b>	7
<b>B</b>	12	4	9		<b>B</b>	3
<b>B/</b>	11	3	10		<b>B/</b>	8
<b>R</b>	4	--	--			
<b>R/</b>	15	--	--			

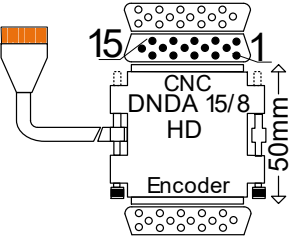

	ZEISS	KEB-S4/ F4	Unidr-SP	DMS2	KEB-X3A	KIN	S4000-TTL	JAT-1	Fagor AXD	ZEISS 2	XENJ8	HIWIN X10
<b>ID-No.:</b>	<b>91ZE22</b>	<b>92PA24</b>	<b>92PA26</b>	<b>92PA28</b>	<b>92PA15</b>	<b>91KI22</b>	<b>91SA32</b>	<b>91JA22</b>	<b>92FR22</b>	<b>92ZE22</b>	<b>91XE22</b>	<b>92HI22</b>
<b>UB</b>	4	12	--	--	12	14	5	--	9	5	--	5
<b>0V</b>	9	13	14	8	13	6	10	6	11	9	15	15
<b>A</b>	7	8	1	11	8	1	7	2	1	7	14	1
<b>A/</b>	2	3	2	6	3	2	1	7	2	2	13	6
<b>B</b>	6	9	3	2	9	3	4	3	3	6	12	2
<b>B/</b>	1	4	4	1	4	4	9	8	4	1	11	7

### DNDA 15/8 HD RJ45 ZENT ► F

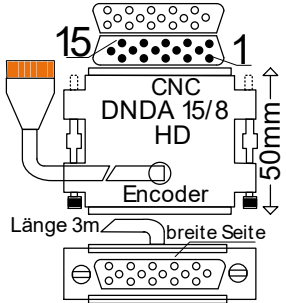
		ETEWE
		<b>ID-No. 92PA27</b>
<b>UB</b>	--	
<b>0V</b>	14	
<b>A</b>	1	
<b>A/</b>	2	
<b>B</b>	3	
<b>B/</b>	4	

### DNDA 15/8 HD HTL SL ▶ Pin 15/ F

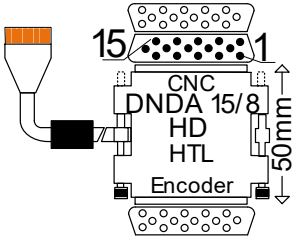
		<b>WMH1</b>
		<b>ID-No. 91WH22</b>
	<b>UB</b>	--
	<b>0V</b>	7
	<b>A</b>	3
	<b>A/</b>	8
<b>B</b>	4	
<b>B/</b>	9	

### DNDA 15/8 HD TWIN ▶ Pin 15/ F

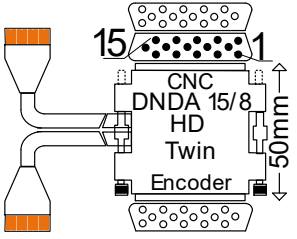
		<b>TWIN LTI X7L</b>	<b>TWIN LTI X7R</b>
		<b>ID-No. 91TL15</b>	<b>91TR15</b>
	<b>UB</b>	3	3
	<b>0V</b>	8	8
	<b>A</b>	2	11
	<b>A/</b>	1	6
<b>B</b>	11	2	
<b>B/</b>	6	1	

### DNDA 15/3+2 HD/ DIN/ T ▶ Pin 15/ M

	SUB D 15	DIN Stecker	Temp-Kabel
<b>ID-No.:</b>		<b>99TA22</b>	
<b>Z+</b>	4	5	
<b>Temp+</b>	5	--	<b>Temp+</b>
<b>GND</b>	6	3	
<b>Z-</b>	9	6	
<b>Temp-</b>	10	--	<b>Temp-</b>

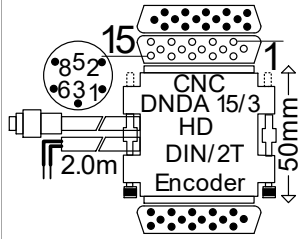

### DNDA 15/ T/ HD/ T ▶ Pin 1/ F

	LTI	LTi2
<b>ID-No.</b>	<b>91LI22</b>	<b>91LI23</b>
<b>T1</b>	14	9
<b>T2</b>	15	10

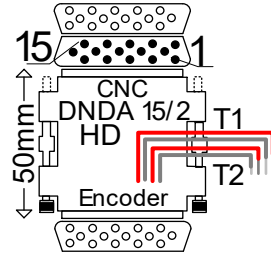

### DNDA 25/ 8/ RJ45 ▶ Pin 25/ F

	Aero	SM-SD2	PA SDI
<b>ID-No.</b>	<b>91AE24</b>	<b>91SM25</b>	<b>94PA25</b>
<b>UB</b>	3	5	--
<b>0V</b>	21	14	--
<b>A</b>	17	21	4
<b>A/</b>	18	8	17
<b>B</b>	14	19	16
<b>B/</b>	15	6	3
<b>R</b>	--	--	5
<b>R/</b>	--	--	18

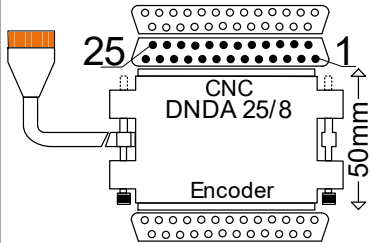

### DNDA 25/ 8/ RJ45 Pin ► 25/ M

	Simovvert-Res	SM140	SM140-5	SIMO 611D	ATLAS COPCO	NUM1050	LC481
ID-No.:	91SV25	92SM25	93SM25	91SI25	91AT25	91NU25	22AT25
UB	--	24	24	1	18	9	--
0V	--	14	14	2	3	21	--
A	3	10	10	3	20	13	20
A/	4	9	9	4	7	25	7
B	6	8	8	6	19	12	19
B/	7	7	7	7	6	24	6
R	9	--	--	--	--	--	--
R/	11	--	--	--	--	--	--

### DNDA 25/8 K ► Pin 25/ M

	K SIMO 611D
ID-No.	91SK25
UB	1
0V	2
A	3
A/	4
B	6
B/	7

DNDA 25/8 T ▶ Pin 25/ M		DNDA 25/ 2/ T ▶ Pin 25/ M		
	<b>SIMO611D</b>		<b>Temp 611D</b>	
	ID-No.	95SI25	ID-No.	93SI25
	UB	1	13, 25	Stift entfernt
	0V	2		
	A	3		
	A/	4		
	B	6		
	B/	7		
(SW)	13	<b>SW</b>	13	
(GR)	25	<b>GR</b>	25	

### DNDA 25/8 TWIN ▶ Pin 25/ M

	611D	25/2-8 611D	EP20	
	ID-No. 97SJ25	91SI92	93EP25	
UB	1	1	RJ45-1	RJ45-2
0V	2	2	13	13
A	3	3	15	21
A/	4	4	14	20
B	6	6	16	22
B/	7	7	17	23

### DNDA 25/3 DIN-R HTL/ DIN ▶ Pin 25/ M

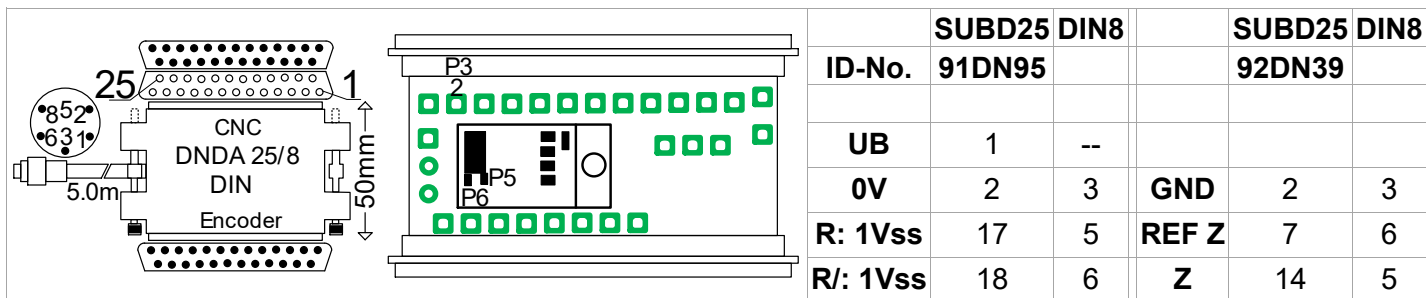

### DNDA 25/7 TBS ▶ Pin 25/ M

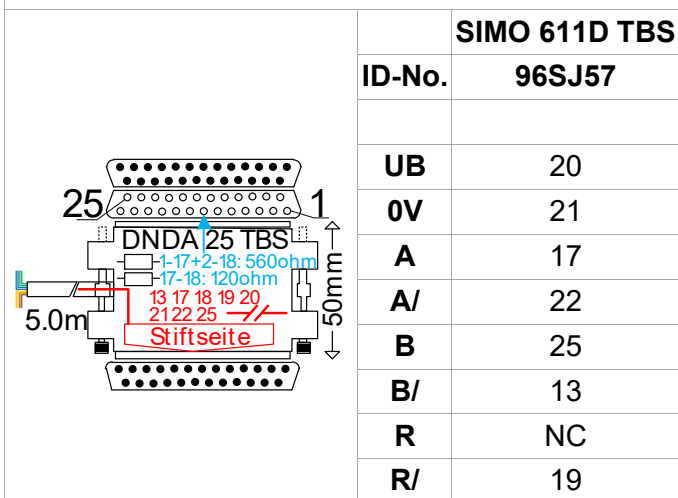

### DNDA 25/ REF ▶ Pin 25/ M

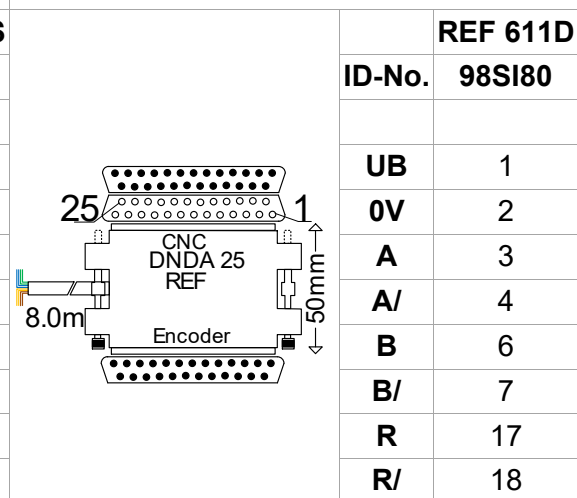

### DNDA 25/8/ RJ45 ► Pin 1/ M

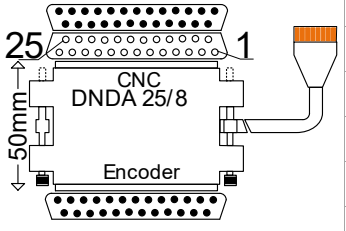
	<b>E SIMO611D</b>	
	<b>ID-No.:</b>	<b>92SI25</b>
	<b>UB</b>	1
	<b>0V</b>	2
	<b>A</b>	3
	<b>A/</b>	4
	<b>B</b>	6
<b>B/</b>	7	

### DNDA 25/8/ RJ45 ► Pin 1/ F

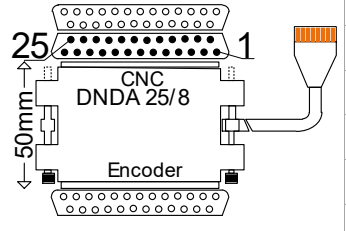
	<b>E SM-SD2 SM-SD2 S/C</b>		
	<b>ID-No.</b>	<b>95SM25</b>	<b>94SM25</b>
	<b>UB</b>	5	9
	<b>0V</b>	14	14
	<b>A</b>	21	21
	<b>A/</b>	8	8
	<b>B</b>	19	19
<b>B/</b>	6	6	

### DNDA 25/8 T ▶ Pin 1/ M

	ET SIMO611D ETV2 SIMO 611D	
	ID-No.:	96SI25
<b>UB</b>	1	1
<b>0V</b>	2	2
<b>A</b>	3	3
<b>A/</b>	4	4
<b>B</b>	6	6
<b>B/</b>	7	7
<b>SW</b>	13	13
<b>GR</b>	25	25

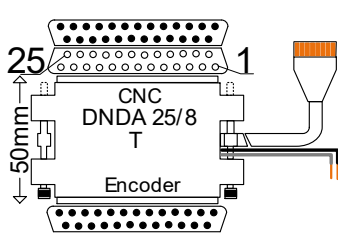

### DNDA 26/8/HD/RJ45 ▶ Pin 26/F

	EL-5V-1	EL-8V-1	NUM MDLU3	NUM MDLU	Reni SR	BM5000	BM5000R	Renishaw
	ID-No. 91EL58	91EL38	91MD28	91MD29	93ZE100	91BM25	91BM26	93ZE25
<b>UB</b>	24	--	--	--	--	2	--	--
<b>0V</b>	25	25	5	5	9	1	--	9
<b>A</b>	1	1	11	17	1	6	21	24
<b>A/</b>	10	10	2	8	19	7	22	6
<b>B</b>	2	2	10	18	2	4	25	7
<b>B/</b>	11	11	1	9	11	5	26	16
<b>R</b>	--	--	--	--	--	--	10	--
<b>R/</b>	--	--	--	--	--	--	1	--

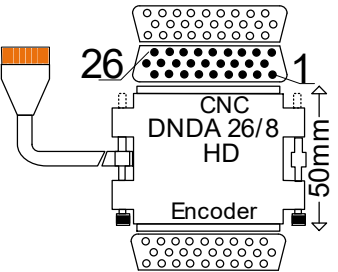

**DNDA 26/26/HD ► Pin 1/ F**

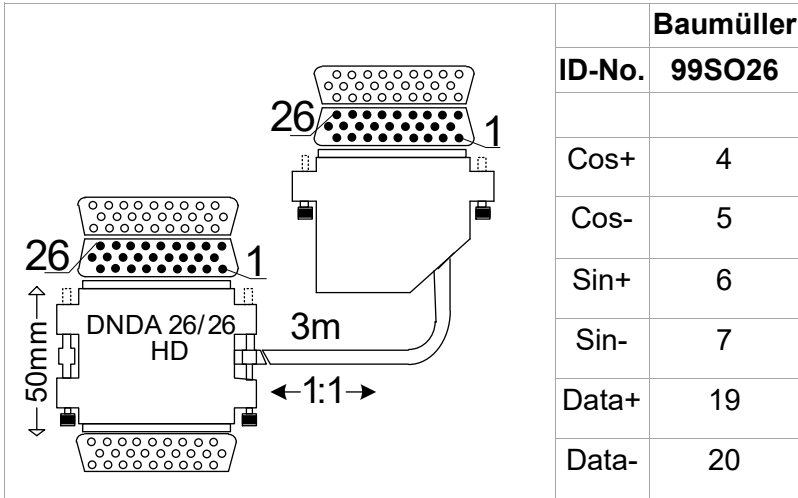

Baumüller	
ID-No.	99SO26
Cos+	4
Cos-	5
Sin+	6
Sin-	7
Data+	19
Data-	20

## D-SUB Komponenten/ D-SUB components



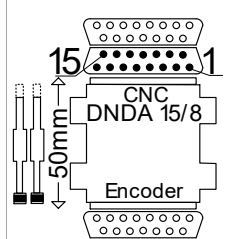



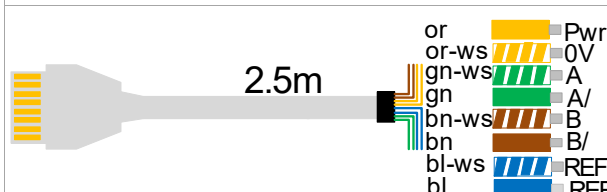
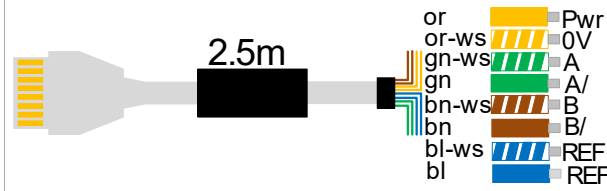

### DNDA 15

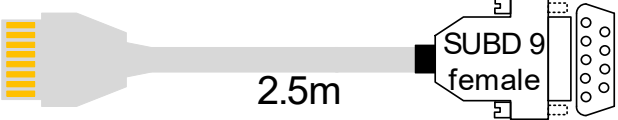











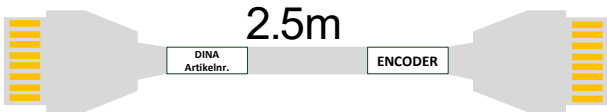





ID-No. 99SO01				
--	--	8	9	
2	4	9	2	
3	3	10	1	
4	8	11	15	
5	6	12	--	
6	5	13	12	
7	10	14	11	
--	--	15	--	

## Anschlusskabel/ Connection cable

DNRJ 45		DNRJ45	DNRJ45R	HTL SL	HTL2	SSI
	ID-No.	97RJ20	98RJ20	95RJ20	91RJ20	97RJ21
		Pwr 5V			Pwr 24V DC	CLK-
		0V		0V	0V	CLK+
		A	A	24V A	24V A	DATA+
		A/	A/	24V A/	24V A/	DATA-
		B	B	24V B	24V B	SET/QUIT
		B/	B/	24V B/	24V B/	Sensor
			R			24VDC
		R/			GND	

<b>RJ45-SUBD9</b>		<b>RS232</b>	<b>SUBD 9</b>	<b>Thimm</b>	<b>RJ</b>	<b>SUBD 9</b>
	<b>ID-No.</b>		<b>91RS21</b>	<b>Andere Adern isoliert</b>		
	0V			or-ws 	1	5
	0V	or-ws 	5	or 	2	5
	TX	bl 	2	gn 	6	3
	RX	bl-ws 	3	bn 	8	2

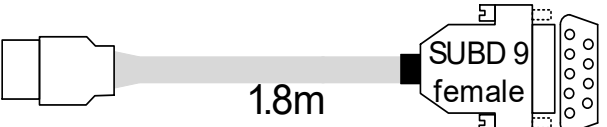
<b>RJ45 – RJ45</b>	<b>Signal/ Index DINA</b>			<b>Pin</b>	<b>Systemc</b>
<b>Standard-Belegung</b>	or-ws 	0V	1		
	or 	PWR	2		
	gn-ws 	A	3		
	gn 	A/	4		
	bl-ws 	REF	5		
	bn-ws 	B	6		
	bl 	REF/	7		
	bn 	B/	8		
	<b>ID-No.:</b>			<b>99RJ20</b>	

<b>USB-SUBD 9</b>			<b>ID-No.</b>
	USB Adapterkabel mit Treiber/ 1,8m	USB adapter cable with booster/ 1,8m	99SO05
<b>USB-USB MIN</b>			
	USB Programmierkabel/ 2,0m	USB programming cable	99SO11

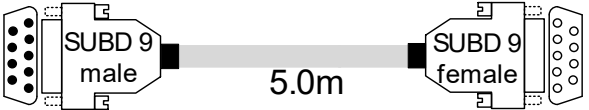
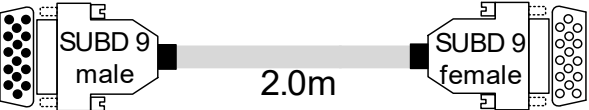
<b>COM-COM</b>			
	SUB D 9Pol, COM Verlängerungskabel /1:1	SUB D 9pin COM extension cable/ 1:1	99SO12
<b>SUBD 15/ HD–SUD 15/ HD</b>			
	SUB HD 15Pol Verlängerungskabel /1:1	SUB HD 15pin extension cable/ 1:1	98VL22

# Abmessungen/Dimensions

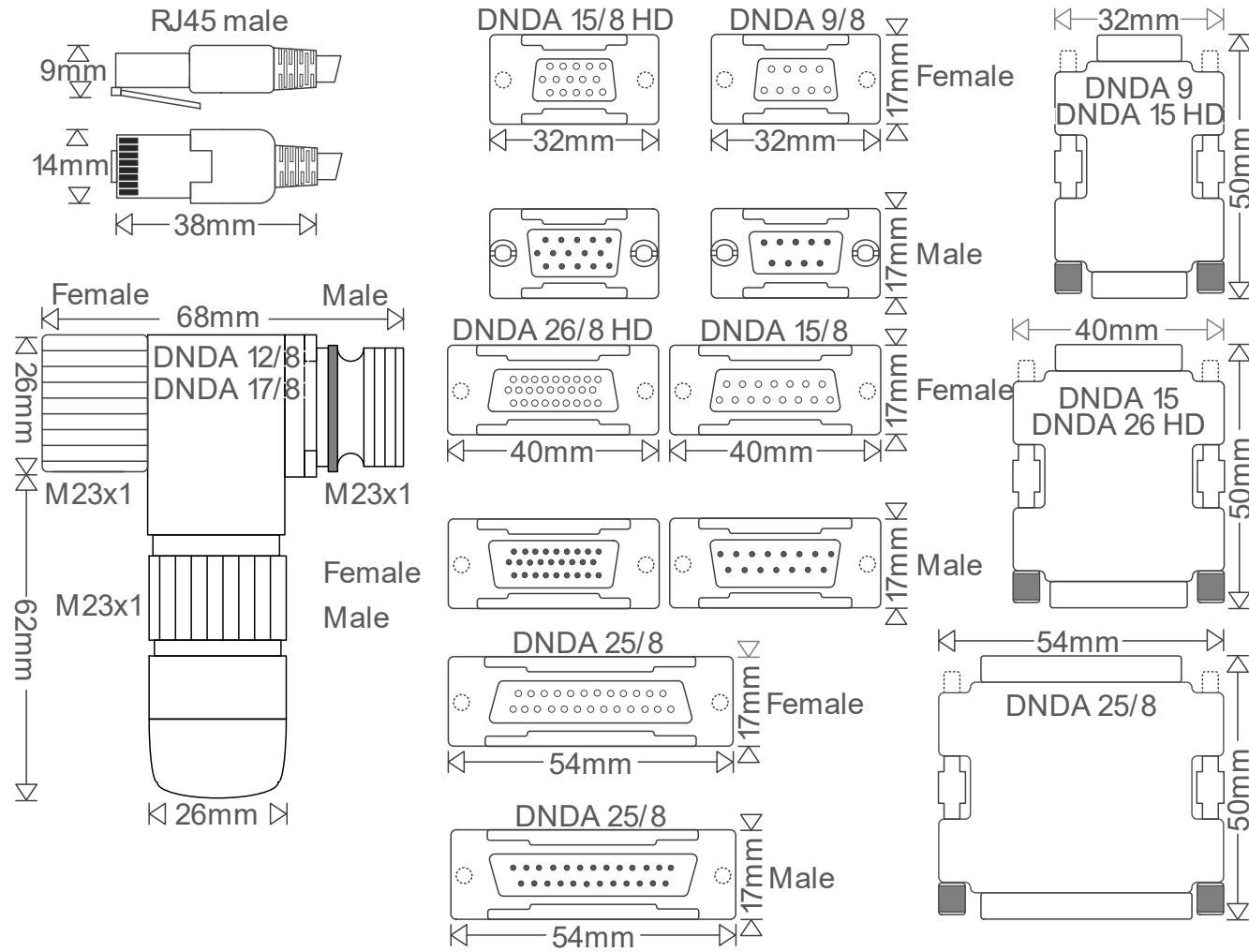

## Technische Daten/Technical data

### Umgebungsbedingungen/ Environmental conditions

Betriebstemperatur Operating temperature	-10 °C bis +60 °C
Zul. Kabelaußentemperatur bei Montage/Handling Permissible external cable temperature during assembly/handling	0 °C bis +50 °C
Rüttelfestigkeit in allen 3 Ebenen Vibration tolerance on all 3 levels	3g, 32 Hz

### Anschlussdaten/connection data

Leitermaterial Conductor material	Kupfer
Material Aderisolierung Core insulation material	Polyethylen (PE)
Kabelaußendurchmesser Cable outside diameter	5,6 mm
AWG	26
Kabellänge (Standard) Andere auf Wunsch Cable's length standard, other on request	2,5m
Biegeradius Bend radius	Installation: 8 x 5,6mm Installiert/installed: 4 x 5,6mm

### Allgemeine Daten/General data

Gehäusematerial Housing material	PC, PA / VO (UL94)
Gewicht Weight	300g

